



Designation: F1828 – 22

## Standard Specification for Ureteral Stents<sup>1</sup>

This standard is issued under the fixed designation F1828; the number immediately following the designation indicates the year of original adoption or, in the case of revision, the year of last revision. A number in parentheses indicates the year of last reapproval. A superscript epsilon ( $\epsilon$ ) indicates an editorial change since the last revision or reapproval.

### INTRODUCTION

The objective of this specification is to describe the test methods used to evaluate the safety and effectiveness of an indwelling ureteral stent, having retention means at the kidney and bladder ends, used for urinary drainage of the kidney to the bladder via the ureter.

This specification includes referee test methods that can be used to evaluate the performance characteristics of ureteral stents. Note that the test methods are not to be construed as production methods, quality control techniques, or manufacturer's lot release criteria. The product parameters addressed by the standard include those determined by the ASTM task group to be pertinent to the product.

### 1. Scope

1.1 This specification covers the referee test methods for evaluating the performance characteristics of a single-use ureteral stent with retaining means at both ends, during short-term use for drainage of urine from the kidney to the bladder. These stents are typically available in diameters of 3.7 Fr to 14.0 Fr, and lengths of 8 cm to 30 cm, and are made of silicone, polyurethane, and other polymers. They are provided non-sterile for sterilization and sterile for single use.

1.2 *Exclusions*—Long-term indwelling usage (over 30 days) is encountered with this product, but not commonly, and is therefore considered an exception to this specification. Similarly, the use of ureteral stents for non-ureteral applications such as nephrostomy and ileostomy is excluded from the scope of this specification. Non-sterile ureteral stents are also excluded due to the variability of hospital sterilization equipment and processes and the resulting effects on ureteral stent characteristics.

1.3 The following precautionary statement pertains only to the test method portion, Section 5, of this specification:

1.4 *This standard does not purport to address all of the safety concerns, if any, associated with its use. It is the responsibility of the user of this standard to establish appropriate safety, health, and environmental practices and determine the applicability of regulatory limitations prior to use.*

<sup>1</sup> This specification is under the jurisdiction of ASTM Committee F04 on Medical and Surgical Materials and Devices and is the direct responsibility of Subcommittee F04.34 on Urological Materials and Devices.

Current edition approved Nov. 1, 2022. Published November 2022. Originally approved in 1997. Last previous edition approved in 2017 as F1828 – 17. DOI: 10.1520/F1828-22.

1.5 *This international standard was developed in accordance with internationally recognized principles on standardization established in the Decision on Principles for the Development of International Standards, Guides and Recommendations issued by the World Trade Organization Technical Barriers to Trade (TBT) Committee.*

### 2. Referenced Documents

- 2.1 *ASTM Standards*:<sup>2</sup>
  - D412 Test Methods for Vulcanized Rubber and Thermoplastic Elastomers—Tension
  - F640 Test Methods for Determining Radiopacity for Medical Use
  - F748 Practice for Selecting Generic Biological Test Methods for Materials and Devices

### 3. Terminology

#### 3.1 *Definitions of Terms Specific to This Standard:*

3.1.1 *test media*—(1) saline, an isotonic solution of pH 5.5 to 7.0; (2) human urine; or (3) artificial urine, a solution of organic and inorganic compounds that closely simulates the chemical and physical properties of normal human urine. Artificial urine may be used as a substitute for human urine to simulate the effects of human urine on ureteral stents.

3.1.2 *bladder retention means*—physical feature of bladder end of stent that prevents movement of stent out of bladder.

3.1.3 *break strength*—peak tensile load required to break stent.

<sup>2</sup> For referenced ASTM standards, visit the ASTM website, [www.astm.org](http://www.astm.org), or contact ASTM Customer Service at [service@astm.org](mailto:service@astm.org). For *Annual Book of ASTM Standards* volume information, refer to the standard's Document Summary page on the ASTM website.

3.1.4 *cross section*—view of stent tube when cut in a plane perpendicular to length of stent.

3.1.5 *distal*—situated away from the point of origin. The distal end of a stent is the end that resides in the bladder, also known as the bladder end.

3.1.6 *drainage holes*—holes in wall of stent tubing that allow flow of urine into and out of lumen of stent.

3.1.7 *dynamic frictional force*—resistance to relative motion between two surfaces during motion. This force is defined as the coefficient of kinetic friction multiplied by the force acting on the surface of the material in a plane perpendicular to the surface.

3.1.8 *elongation*—expressed as a percent, is equal to the change in length of a sample of tubing at failure divided by its original length. Stretching of the tubing is produced by tensile loading.

3.1.9 *French size*—scale used to indicate size of tubular devices, each unit being approximately equal to 0.013 in. or 0.33 mm in diameter. Typical label French sizes are as follows:

French Size	Outside Diameter in. mm
3.7	0.050, 1.23
4.5	0.060, 1.50
4.7	0.061, 1.57
6.0	0.079, 2.00
7.0	0.092, 2.33
8.0	0.105, 2.67
8.5	0.112, 2.83
10.0	0.131, 3.33
14.0	0.183, 4.66

3.1.10 *kidney retention means*—physical feature of kidney end of stent that prevents movement of stent out of the kidney.

3.1.11 *length*—distance between the most proximal portion of the bladder retention means and the most distal portion of the kidney retention means when the stent is laying on a flat surface with the main shaft straight (see Figs. 1 and 2).

3.1.12 *lumen*—channel within a tube.

3.1.13 *proximal*—situated toward the point of origin. In the urinary tract, the kidney is considered to be the point of origin. The proximal end of a stent is the end that resides in the renal pelvis, also known as the kidney end.

3.1.14 *radiopacity*—property indicating ability of device to absorb X-ray energy, allowing device to be seen in a radiograph or fluoroscopic image.

3.1.15 *referee test method*—method cited in the published specification for the device. This method will be used when the performance of the ureteral stent is to be evaluated. The manufacturer need not use this referee test method for inspection and quality control.

3.1.16 *retention strength*—force required to overcome the retaining means on a stent.

3.1.17 *sterility*—state of being free of microorganisms. For purposes of this specification, sterility is defined as freedom from microorganisms when tested according to the methodology defined by the USP for nonparenteral devices.

3.1.18 *tolerances*—allowable deviation from a standard size. The tolerance for the length of a ureteral stent is  $\pm 0.5$  cm (0.197 in.). The tolerance for the specified French size of a ureteral stent is  $\pm 0.01$  cm (0.004 in.), or approximately  $\frac{1}{3}$ -French.

3.1.19 *ureteral stent*—indwelling tubular device that resides in the kidney, ureter, and bladder containing means for retaining ends of tube in kidney and bladder.

4. Requirements

4.1 *Biocompatibility*—Ureteral stents shall be tested in accordance with the appropriate biological tests contained in Practice F748 or similar guidance established by the U.S. Food and Drug Administration (FDA) or International Organization for Standardization (ISO).

5. Special Precautions

5.1 The following cautionary comments recognize the sensitivity of the materials of construction to potential environmental conditions. These are outlined here to point out potential situations that could adversely affect the performance of the stent during testing.

5.1.1 Care should be taken during testing and use to prevent damage to the stents. Such damage can be caused by abrasion and contact with sharp objects or chemical products.

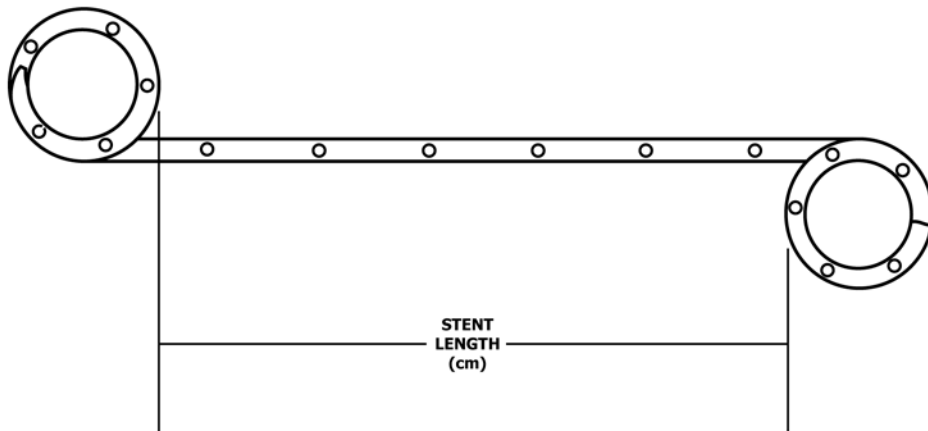

FIG. 1 Determination of Stent Length

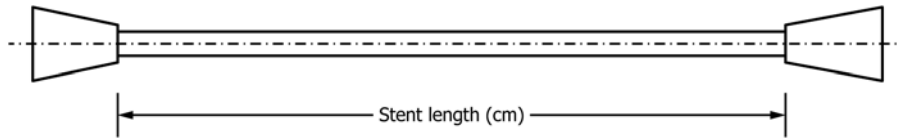

FIG. 2 Determination of Stent Length (alternative stent anchorage design)

5.1.2 Stents should be kept away from generators, electric motors, diathermy machines, and fluorescent lights because the ozone produced may attack elastomeric materials. This applies to both storage and handling.

5.1.3 To help avoid contamination of the stents, proper handling precautions should be observed.

**6. Test Methods**

*6.1 General Guidelines:*

6.1.1 Test samples should consist of actual ureteral stents, not material slabs.

6.1.2 Use statistically valid sample sizes in all tests.

6.1.3 Package all stent test samples and sterilize using the method of sterilization intended to be used for product when it is sold.

6.1.4 Expose test samples to test media at  $37 \pm 3$  °C for an appropriate duration (for example, 30 days). When test media is artificial urine, use either of the formulations listed in [Annex A1](#).

6.1.5 Maintain pH of test media in the range of 5.5 to 6.5 at all times. Test media should be replaced weekly.

6.1.6 Perform tests prior to and after soaking for an appropriate duration (for example, 30 days). For products with intended chemical/mechanical changes such as softening, swelling, etc., conduct initial mechanical testing only after sufficient soaking time has elapsed that allows such chemical/mechanical changes to occur.

6.1.7 Dynamic frictional force test samples need only be soaked in saline test media for 1 min prior to testing. This test need not be repeated after 30 days.

*6.2 Retention Strength:*

6.2.1 *Scope*—This test method measures the ability of a ureteral stent to resist migration. It can be used for testing the proximal or distal ends of a ureteral stent.

*6.2.2 Summary of Test Method:*

6.2.2.1 The apparatus is set up as shown in [Fig. 3](#). Clearance between the outside diameter of the stent and inside diameter

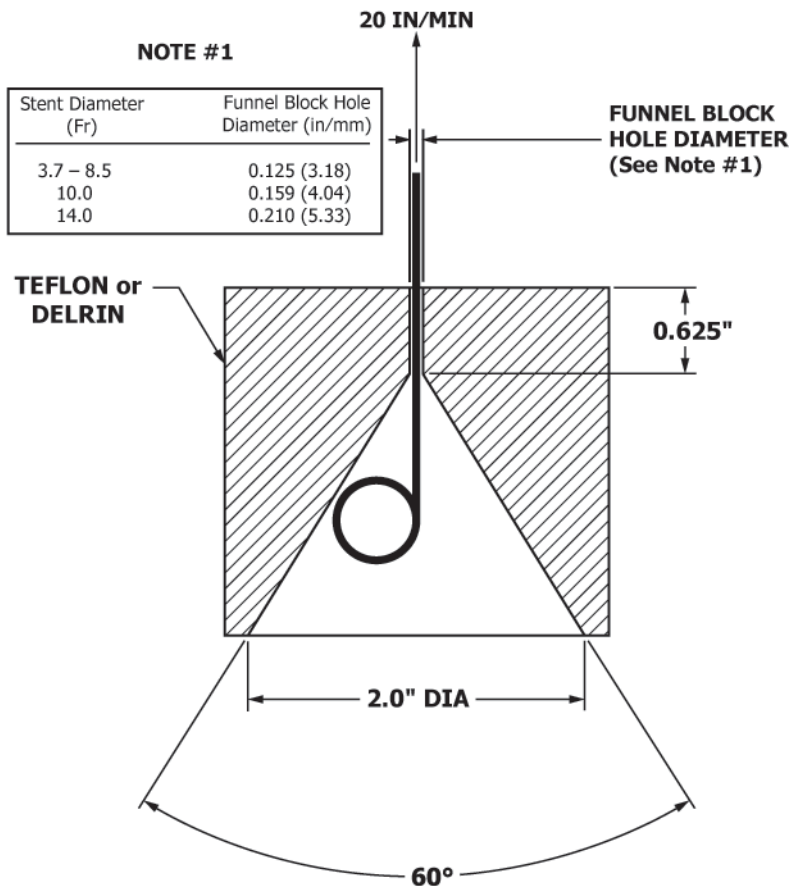

FIG. 3 Funnel Block for Retention Strength Test